

ZHUOTE  
MANUFACTURING CO.

# ZT75W-S



# DIGGING FOR THE EARTH



## Guangzhou (Marketing Center)

Contact number: 1363788 5827  
Address: No. 1264, East Zhuji Engineering Machinery, Zhongshan Avenue, Tianhe District, Guangzhou.

## Xingtai (Production Base)

Contact number: 0319-8587888  
Address: Yangguang Industrial Zone, Linxi District, Xingtai City, Hebei Province

# ZT75W-S WHEEL EXCAVATOR

▼ Technical Parameter

## Engine

Model	Yanmar 4TNV94L
Type	In-line
Inhale air	Natural inspiration
Cylinder number	4
Bore	94mm
Piston stroke	110mm
Rated power	36.2kw

## Working weight (operator, lubricant, coolant, full fuel tank and standard configuration)

Swing arm	3200mm
Bucket lever	1800mm
Scraper	0.25m <sup>3</sup>
Working weight	6.2ton

## Driving device and brake

Steering control	Hydraulic steering wheel control
Type of drive	Fluid drive
Walking motor	Axial plunger hydraulic motor
Walking speed (high/low)	27/10km/h
Service brake	Multi-disc brake
Parking braking	Multi-disc brake

## Main pump

Type	Axial piston pump
Maximum flow	140L/min

## Fuel tank capacity

Fuel tank	124L
Hydraulic oil tank (dipstick level)	110L

## Whole machine size

## Hydraulic motor

Walking motor	Axial plunger type×1
Operating brake	Wet multi-disc brake

## Rotary system

Type of drive	Fluid drive
Deceleration mechanism	Planetary gear deceleration
Operating brake	Wet multi-disc brake
Spin velocity	12.5rpm

## Maximum excavation force (ISO)

Scraper	85kN
Bucket lever	62.5kN

## Technical parameter

A	Transportation length	6250 mm
B	Transportation width	2205 mm
C	Transportation height	2882 mm
D	Gyroradius	2430 mm
E	Wheelbase (of a vehicle)	2100 mm
F	Wheel tread	1685 mm
G	Maximum excavation radius	6410 mm
H	Maximum excavation depth	3500 mm
I	Maximum excavation height	6518 mm
J	Maximum unloading height	4700 mm
	Turntable height from the ground	1040 mm
	Turntable width	2040 mm
	Turntable tail length	1600 mm
	min. ground clearance	290 mm
	Distance from the center of the rotary center supporting drive wheel	1250 before/870mm after

## Working range

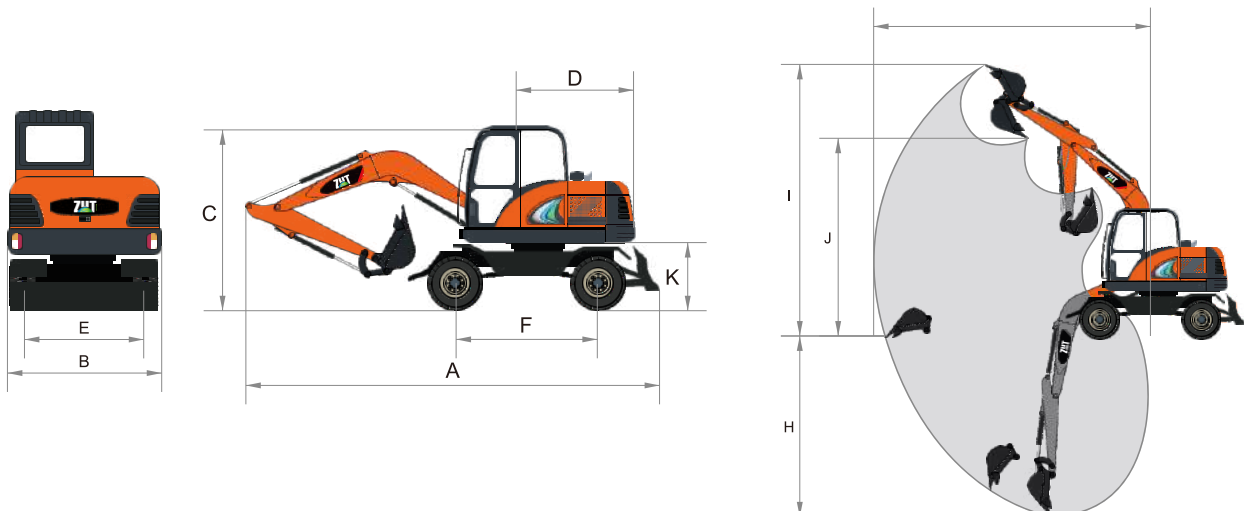



ZHUOTE  
MANUFACTURING CO.

# ZT85W



# ROBUSTLY AND DURABLE

#### Guangzhou (Marketing Center)

Contact number: 1363788 5827  
Address: No. 1264, East Zhuji Engineering Machinery, Zhongshan Avenue, Tianhe District, Guangzhou.

#### Xingtai (Production Base)

Contact number: 0319-8587888  
Address: Yangguang Industrial Zone, Linxi District, Xingtai City, Hebei Province



# ZT85W WHEELED EXCAVATOR

▼ Technical Parameter

Engine	
Model	Yangma 4TNV98L
Type	In-line
Inhale air	Natural inspiration
Cylinder number	4
Bore	φ98mm
Piston stroke	110mm
Rated power	46.3kw
Working weight	
Swing arm	3400mm
Bucket lever	1900mm
Scraper	0.27m <sup>3</sup>
Working weight	7.3ton
Driving device and brake	
Steering control	Hydraulic steering wheel control
Type of drive	Fluid drive
Walking motor	Axial plunger hydraulic motor
Walking speed (high/low)	30/10km/h
Service brake	Multi-disc brake
Parking braking	Multi-disc brake
Main pump	
Type	Axial piston pump
Maximum flow	156L/min
Fuel tank capacity	
Fuel tank	124 L
Hydraulic oil tank (dipstick level)	110 L
Whole machine size	

Hydraulic motor	
Walking motor	Axial plunger type×1
Operating brake	Wet multi-disc brake
Rotary system	
Type of drive	Fluid drive
Deceleration mechanism	Planetary gear deceleration
Operating brake	Wet multi-disc brake
Maximum excavation force (ISO)	
Scraper	38kN
Bucket lever	29kN
Technical parameter	
A Transportation length	6450mm
B Transportation width	2205mm
C Transportation height	2885mm
D Gyroradius	2430mm
E Wheelbase (of a vehicle)	2400mm
F Wheel tread	1685mm
G Maximum excavation radius	6770mm
H Maximum excavation depth	3600mm
I Maximum excavation height	6740mm
J Maximum unloading height	4780mm
Turntable height from the ground	1040mm
Turntable width	2060mm
Turntable tail length	1600mm
min. ground clearance	290mm
Distance from the center of the rotary center supporting drive wheel	1433 before/962mm after
Working range	

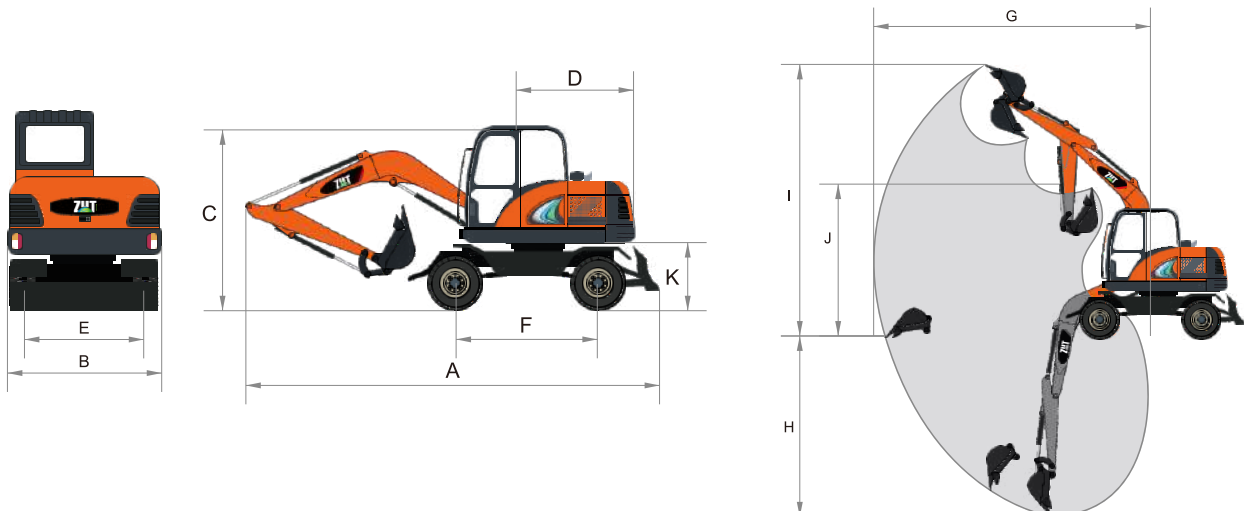



# ZT95W



**WEIGHT  
MORE  
TITAN POWER**



# ZT95W

WHEEL EXCAVATOR

NATIONAL BRANDCAST VALUE

## FIERCE DIGGER

DIGGER



- 01 REAR PART** High configuration and high performance  
Modular design of components.  
The fuel filter is equipped with an oil-water separator.



- 02 ERGONOMIC SEAT** Comfortable and convenient  
Suspension safety seat. New large-screen LCD instrument panel.  
Broad driving vision. High air volume circulating air conditioning system.



- 03 IMPORTED FITTINGS** Efficient, stable and reliable  
Import hydraulic pump flow upgrade. Imported Yangma engine.  
The stability of imported wet axle system is strengthened.



- 04 EXTENDED WORKING MECHANISM**  
Walking with two tires. New optimized transmission system.  
New type of bright and wide-angle lighting under working conditions.



### Money-Saving

2 years, 3000 hours.  
Free warranty service.



### Time-Saving

Customer service hotline is  
available 365\*24, High-efficiency  
after-sales response



### Care-Free

Assurance from manufacturer  
guidance and oem-parts supply



### Hassle-Free

Enjoy the professional service  
of the after-sales  
Wholeheartedly, meticulously



# ZT95W WHEELED EXCAVATOR

## ▼ Technical Parameter

Engine	
Model	Yangma 4TNV98T
Type	In-line
Inhale air	Natural inspiration
Cylinder number	4
Bore	φ98mm
Piston stroke	110mm
Rated power	56.5kw
Working weight (operator, lubricant, coolant, full fuel tank and standard configuration)	
Swing arm	3720mm
Bucket lever	1900mm
Scraper	0.29m <sup>3</sup>
Working weight	8.2ton
Driving device and brake	
Steering control	Hydraulic steering wheel control
Type of drive	Fluid drive
Walking motor	Axial plunger hydraulic motor
Walking speed (high/low)	30/10km/h
Service brake	Multi-disc brake
Parking braking	Multi-disc brake
Main pump	
Type	Axial piston pump
Maximum flow	178L/min
Fuel tank capacity	
Fuel tank	124L
Hydraulic oil tank (dipstick level)	110L
Whole machine size	

Hydraulic motor	
Walking motor	Axial plunger type×1
Operating brake	Wet multi-disc brake
Rotary system	
Type of drive	Fluid drive
Deceleration mechanism	Planetary gear deceleration
Operating brake	Wet multi-disc brake
Spin velocity	9rpm
Maximum excavation force ( ISO )	
Scraper	46kN
Bucket lever	33kN
Technical parameter	
Transportation length	6625mm
Transportation width	2400mm
Transportation height	3150mm
Gyroradius	2370mm
Turntable height from the ground	1035mm
Turntable width	2200mm
Turntable tail length	1825mm
min. ground clearance	310mm
Distance from the center of the rotary center supporting drive wheel	1370 before/1030mm after
Wheelbase (of a vehicle)	2400mm
Wheel tread	1815mm
Maximum excavation radius	6725mm
Maximum excavation depth	3950mm
Maximum excavation height	7070mm
Maximum unloading height	5040mm
Working range	

Unit: mm



Unit: mm

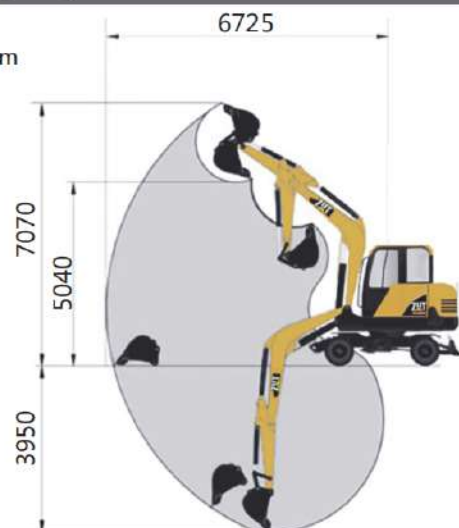





# ZT60W

# GRAND LAUNCH



- Imported yanmar engine with high efficiency and energy saving
- Automatic transmission wave box that is operation free
- Accurate and robust imported full hydraulic system
- Imported wet brake bridge system
- Smooth and soft top set-up of the whole vehicle
- A reinforced structural design for the whole vehicle

# Focused on innovation

Superior Quality    Extraordinary Performance

## REAR SIDE

HIGH-END CONFIGURATION  
GREAT PERFORMANCE



- Modular design with easy maintenance



- Advanced fuel filter with oil-water separator



- Equipped with air filter for the harsh jobsite



## WELL-KNOWN COMPONENTS

HIGH EFFICIENCY  
RELIABLE PERFORMANCE



- Imported rexroth hydraulic pump



- Imported yanmar engine



- Imported wet-type brake axle

## OPERATE WITH FUNCTIONAL DESIGN

HIGH-END CONFIGURATION  
EASY TO OPERATE



- Large LCD touch screen



- Removable floor mat



- Throttle knob simple in use



- High-performance radiator



- Vehicle-mounted multimedia player

## ERGONOMICALLY DESIGNED CABIN

ADVANCED TECHNOLOGY  
RELIABLE COMPONENTS



- Spacious and luxurious multi-functional cab



- Emergency hammer and Fire extinguisher



- Spacious and luxurious multi-functional cab

# High-quality after-sales service



### Money-Saving

2-year 3,000-hour free warranty service commitment



### Time-Saving

400 customer service hotline is available 365\*24, High-efficiency after-sales response



### Care-Free

Assurance from manufacturer guidance and oem-parts supply



### Hassle-Free

Enjoy the professional service of the after-sales Wholeheartedly ,meticulously



# Advanced Technology

High efficiency    Durable in use

## EXCAVATING RANGE

UNIT: mm

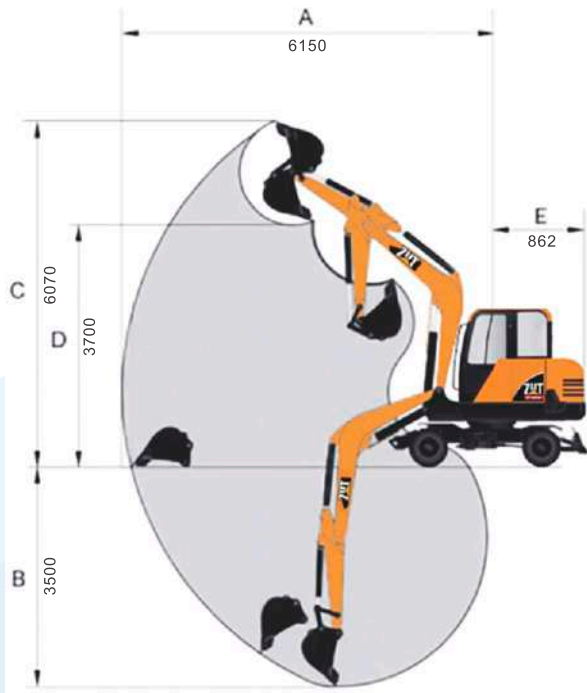

## DIMENSIONS

UNIT: mm

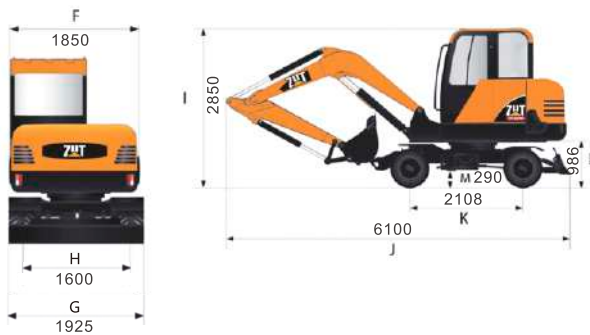

## PARAMETER SPECIFICATION

Main Specifications		Parameter and Configuration
<b>Engine</b>		
Model		Yanmar 4TN98L
Form	Type	Naturally aspirated diesel engine
	Air Cylinder	Four-poles inline
Rated power		46.3kW
Cylinder diameter		98mm
Travel distance		110mm
<b>Hydraulic system</b>		
Main pump	Type	Axial piston pump
	Maximum flow	2×60L/min
Hydraulic motor	Motor power	Axial piston x1
	Rotary braking	Wet multi-disc brake
Fuel tank capacity	Hydraulic oil container	72L
	Fuel tank	120L
<b>Rotary system</b>		
Drive mode		Hydraulic drive
Retarding mechanism		Planetary reducer
Rotational speed		8.7rpm
<b>Braking facilities and braker</b>		
Steering control		Pedal and steering wheel control
Drive mode		Hydraulic drive
Traveling speed	Maximum	30km/h
	Minimum	10km/h
Operational Brake		Hydraulic drive
Parking brake		Wet multi-disc brake

Technical Specifications		Parameter and Configuration
Operating weight		5.55 ton
Boom length		3000 mm
Bucket rod length		1600 mm
Rated dig volume		0.21m <sup>3</sup>
<b>Oil Cylinder</b>		
Movable arm		110×60×712mm
Bucket rod		85×55×873 mm
Bucket		80×50×600 mm
Dozer blade		110×60×150mm
<b>(ISO) Maximum Digging Force</b>		
Bucket		35.6kN
Bucket rod		26.9kN
<b>Overall Dimensions and Working Range</b>		
Transportation Clearance	L*W*H	6100×1925×2850mm
Turning radius		2350mm
Rotary table	Terrain clearance	986mm
	Width	1850mm
	Tail length	1650mm
Distance from rotary center to driving wheel center		Front 1246mm / Back 862mm
Wheel base		2108 mm
Tread		1600mm
Maximum digging radius		6150mm
Maximum digging depth		3500mm
Maximum digging height		6070mm
Maximum dumping height		3700mm

2-year 3,000-hour  
free warranty service commitment

Product Details



ZHTE QR code



**Guangzhou (Sales Center)**

**Add:** Zhuji, Lianxi Road, Zhongshan Avenue,  
Tianhe District, Guangzhou

**C C:** 400-156-6869

**Te l:** 86-20-32233445

**Fax:** 86-20-82029711

**E-mail:** ZWZC88@126.com

**Xingtai (Production Base)**

**Add:** Sunshine Industrial Zone, Linxi District,  
Xingtai City, Hebei Province

**C C:** 400-156-6869

**Te l:** 86-319-8572868

**Fax:** 86-319-8587888

**Web:** www.zwhydraulic.com





# 大力牛魔王D01

——Smart vehicle for terminal distribution——



# Part A

## 大力牛魔王 D01 Exhibition



- Battery: 9.98kWh
- Endurance: More than 120km
- Cargo volume : Approx. 1.8m<sup>3</sup>



Note: The picture is not the final mass production version, subject to the actual vehicle

■ **Market positioning**

**Smart vehicle for  
terminal distribution**

■ **Key sale point**

**Safety-Dexterity-Comfort**

■ **Core competitors**

**None (replacement tricycle market)**

■ **Target users**

**Maintenance car, production tools, home service, single  
person outdoor tool car**



# Basic parameters

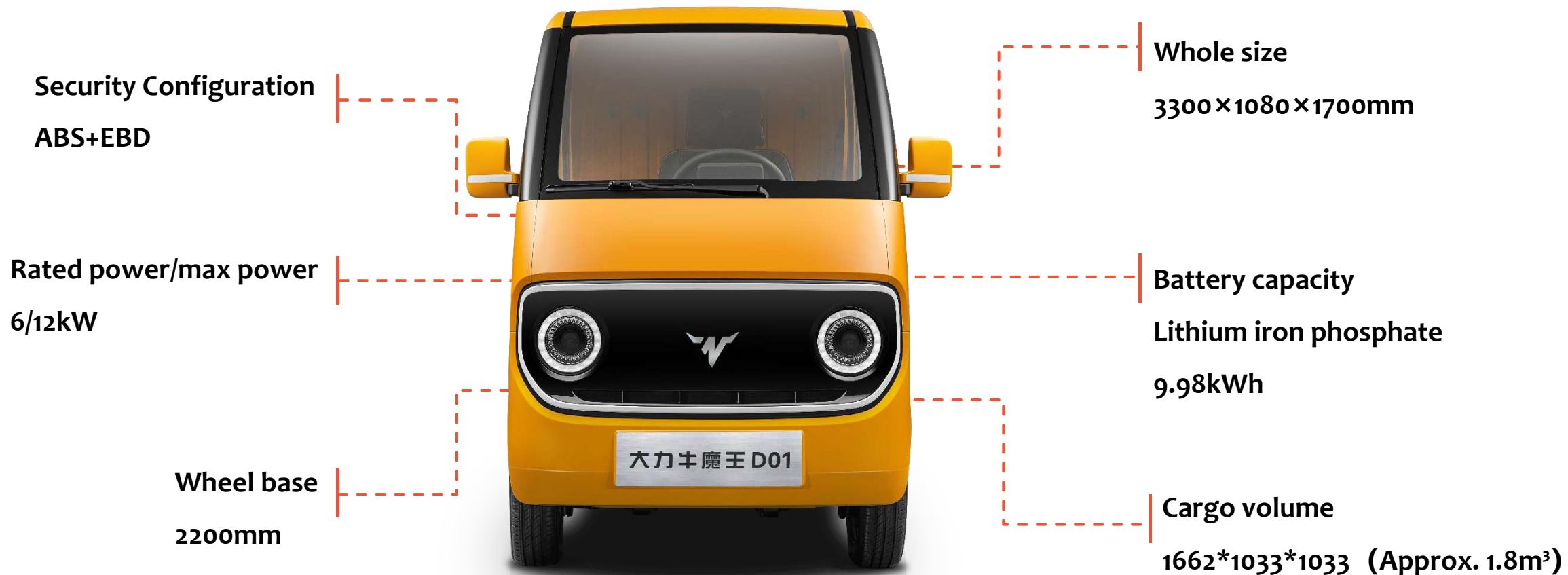

Note: The picture is not the final mass production version, subject to the actual vehicle.

# Part B

**Product sale point**

## Smart vehicle for terminal distribution

### Safe

- Low cost
- Great security
- Security Compliance
- Security technology
- Safety body

### Dexterous

- Small figure
- Wide purpose
- Flexible trafficability
- Economic dexterity
- Flexibility of way right
- Community dexterity

### Comfortable

- Innovate
- Enjoy
- Comfort configuration
- Comfort drive
- Comfort appearance
- Comfort service
- Comfort loading



## Security Compliance



- New energy logistics vehicles that are being developed for terminal distribution;
- **Insurance and license plate are available to provide better protection for drivers.**

## Safety body



- Integrated high-strength body
- **Pass the collision test of three wheels and ten vehicles**
- **First class accessory supply**

## Security technology



- Front disc and rear drum brake
- Strong braking stability and anti roll ability
- **Standard system ABS electronic brake force distribution EBD, strong anti roll ability, steady and stable travel**
- **IP67 waterproof standard**
- 24x7 data monitoring platform

## Flexible trafficability



- 1080mm narrow body with a small turning radius of about 4m
- Flexible crossing streets and alleys
- **Better than tricycle, more smooth than minivan.**

## Flexibility of way right



- **Regular license plate of new energy vehicles, no need to worry about traffic restrictions**
- The express tricycle will be transformed into a formal terminal logistics vehicle, and the affordable and compliant D01 model is the best choice

## Economic dexterity

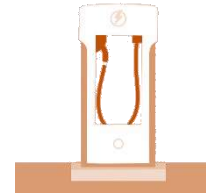

- Pure electric drive, only 3 cents per kilometer. The 120km long endurance makes you feel free to move forward.
- **Enjoy the purchase tax exemption policy, and earn money at a low cost.**

## Community dexterity



- APP platform interaction

## Comfort configuration



- The whole vehicle is equipped with suspension instrument, Bluetooth, microphone, USB charging interface, etc. as standard, adding some fun to the boring journey
- **It can be equipped with warm air conditioner, cold air conditioner, cold and warm air conditioner, and electronic power assistance, so as to be free from cold and heat, wind, frost, rain, snow, and easy to control**

## Comfort Drive



- **The integrated carrying body+independent cargo box structure design makes the vehicle travel very smoothly**
- The integrated body has high safety, comfortable driving, no fear of extreme weather, normal attendance, non-stop orders and revenue

## Comfort service



- Vehicle warranty for 3 years or 100000 km
- 5-year or 200000 km extra long warranty for three electricity system
- Users can use the car happily without worries.

Note: Warranty period of whole vehicle is 3 years or 100000 km, whichever comes first.

Warranty of three electricity system: 5 years or 200000 km, whichever comes first.



## 58 barrels of drinking water in one trip

- Container is about 1.8m<sup>3</sup>, Take the 5L water barrels as an example, 58 barrels can be delivered per trip, 45% more than the tricycle;
- Faster, more loading will bring extra income.

## 290KG, No problem at all

- High strength leaf spring rear suspension, high load bearing integrated electric drive axle are used to make the load capacity reach **290kg**
- Meet the use requirements of express delivery, expand the demand for vehicles to distribute daily loads in the same city

## Protect you and your package

- Full seal transportation of goods package
- **It can ensure road traffic safety and prevent goods from being damaged**





## Beautiful model, considerable income

- The front face is simple and cute
- Highlighted black grille with colored trim
- Very visual impact.



## Attract eyeballs

- The round lights are flexible in technology and distributed at both ends of the vehicle
- The interior of the lamp is full of details, shining like diamonds.



## Wonderful back

- The tail shape is simple and grand, and the design is square and small
- It echoes the design of the front face.

## Comfortable· Comfort appearance



- The interior design is clearly layered, and the functional layout is practical and complete. The IP middle trim panel full of technology adds a touch of vitality to the interior.
- The compact and delicate screen is full of functions to meet daily needs. The seats are made of dark grey fabric texture, durable and wear-resistant.

# Part C

## Benchmarking of competitive products

- According to the competition pattern and market positioning, the direct competitors are:

## Direct competitor



Express semi van tricycle

## Indirect Competitor



Freight tricycle

## Potential competitor



Express two  
wheeled  
vehicle



# Overall parameter benchmarking

- 大力牛魔王 01 is the same as or superior to competitors in terms of endurance, safety, carrying capacity and comfort.

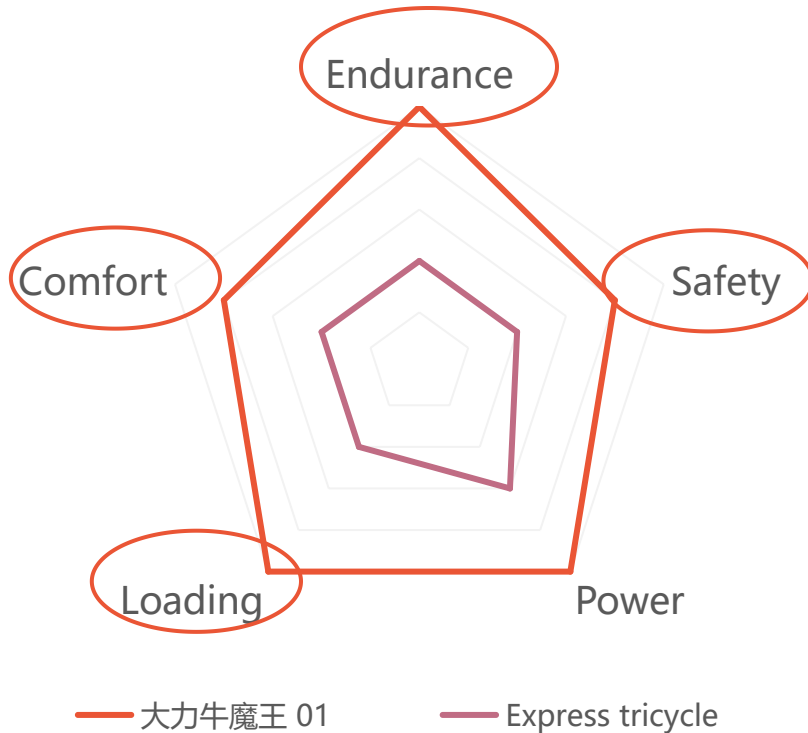

Parameter	大力牛魔王 D01	Express tricycle
Whole size	3300×1080×1700	2970×1000×1600
Container size	<b>1662×1033×1033 (about 1.8m<sup>3</sup>)</b>	1400×950×950 (1.2m <sup>3</sup> )
Loading capacity	<b>290kg</b>	200kg
Mass weight	<b>615kg</b>	200kg
Battery brand	<b>Guoxuan High Tech</b>	Mainly lead acid
Battery capacity	<b>9.98kWh</b>	60V58A
Power kW	6/12	0.8~1.5
Endurance	<b>≥120</b>	Within 50
Max speed (km/h)	≥71	15
Steering	<b>Mechanical steering (optional electric power)</b>	Manual steering
Chassis suspension	Front McPherson type independent rear leaf spring	Front hydraulic rear steel plate
AC	<b>Optional</b>	No
Remote Query	<b>Optional</b>	No

## More battery capacity & Longer endurance

大力牛魔王D01



Express tricycle



# VS

Guoxuan High Tech	Battery brand	Plumbic acid
Lithium iron phosphate	Battery type	Lithium iron phosphate
9.98	Battery capacity/Kwh	Uncertain
≥120	Endurance (constant speed) /km	Within 50
5Years 20000Kms	Three electricity warranty	1 year

## Better safety performance & More stable braking

大力牛魔王D01



Express tricycle



# VS

Front disc and rear drum	Brake	Front disc and rear drum
<b>ABS+EBD</b>	Brake assist	No
<b>Yes</b>	Vehicle test	No

## Carry **more** & Loading **more**

大力牛魔王D01



Express tricycle



# VS

<b>1662×1033×1033</b> <b>(about 1.8m<sup>3</sup>)</b>	<b>Container size</b>	<b>1400×950×950</b> <b>(1.2m<sup>3</sup>)</b>
<b>3300×1080×1700</b>	<b>Whole size</b>	<b>2970×1000×1600</b>
<b>290kg</b>	<b>Loading capacity</b>	<b>200kg</b>

More loads **45%**



AC brings **more** comfortable & **More** comfortable closed body

大力牛魔王D01



Express tricycle



VS

Optional	A/C	No
Remote query and remote diagnosis	Remote Query	No

# Part D

## Detail display

# Details of product parameters



		Parameters Details				
Model		大力牛魔王D01-Van				
Version		Basic Version	High version	Top version	High version-I	Top version-I
Basic parameters	Size (mm)	3300×1080×1700				
	Container size mm	1662×1033×1033 (约1.8m³)				
	Wheelbase (mm)	2200				
	Total weight kg	945				
	Curb (kg)	/	590	615	590	615
	Loading weight (kg)	/	290	265	290	265
	Endurance (km)	≥80	≥120	≥120	≥120	≥120
	Max speed km/h	≥71				
	0~50km/h Acceleration time (s)	≤10				
	Maximum climbing slope %	≥20				
	Ground clearance under full load mm	≥131				
	No. of Doors	2				
Passenger	1					
Battery	Type	Lithium iron phosphate				
	Capacity (kw-h)	6	9.98	9.98	9.98	9.98
	Voltage (V)	96	96	96	96	96
	Density (Wh/kg)	/	≥114	≥114	≥114	≥114
	Charger (kW)	2.2				
	Charge time (h)	/	<8	<8	<8	<8
	Battery thermal management	Natural air cooling				
Battery pre-heating system (charging)	●					
Motor	Type	Permanent magnet synchronization				
	Rated/peak power kW	6kW/12kW				
	Rated/peak torque N.m	10/61				
Chassis	Drive mode	Rear drive				
	Suspension	Front McPherson independent rear leaf spring				
	Mechanical steering	●	●	-	●	-
	Electric power CEPS	-	○	●	○	●
	Braking system	Front disc rear drum				
	Tyre size	135/70R12				
Steel hub	●					

# Details of product parameters



		Parameters Details				
Model		大力牛魔王D01-Van				
Version		Basic Version	High version	Top version	High version-I	Top version-I
Appearance and interior decoration	Color	White/Silver			-	-
	Right side opposite door	●	●	●	●	●
	Exterior rearview mirror	Manual adjustment				
	Driver's side sun visor	●				
	Seat material	Textile				
	Seat adjustment	Front and rear adjustable, backrest angle adjustable, overall reversible				
	Container floor	Metal				
	Ceiling	●				
Electrical device	Cargo compartment side wall+rear bumper	-	○	●	○	●
	Single warm air	-	●	-	●	-
	Air conditioner	-	○	●	○	●
	Halogen headlamp	●				
	Headlamp height adjustment	●				
	High-mounted brake lamp	●				
	USB Interface (1个)	●				
	Speaker	1				
Safety device	Bluetooth	●				
	Combination instrument	LCD meter				
	Car window	Manual window				
	T-BOX	●				
	Low speed warning tone	●				
Intelligent configuration	Three-point type seat belt	●				
	ABS+EBD	●				
	Mobile phone and car integration	●				
Others	Remote query	●				
	Remote diagnosis	●				
	Car kit	●				
	Charge gun	●				
	Warning triangle	●				
	Reflective Vest	●				
	Special color&special logo	-	-	-	●	●

1. "●" indicates that the configuration is available, "○" indicates that the configuration is optional, "-" indicates that the configuration is not available, and "/" indicates that the configuration has not been finally confirmed.

2. If the configuration is changed, the final explanation of the manufacturer shall prevail.







# Interior and exterior decoration display



Note: The picture is not the final mass production version, subject to the actual vehicle



# Interior and exterior decoration display

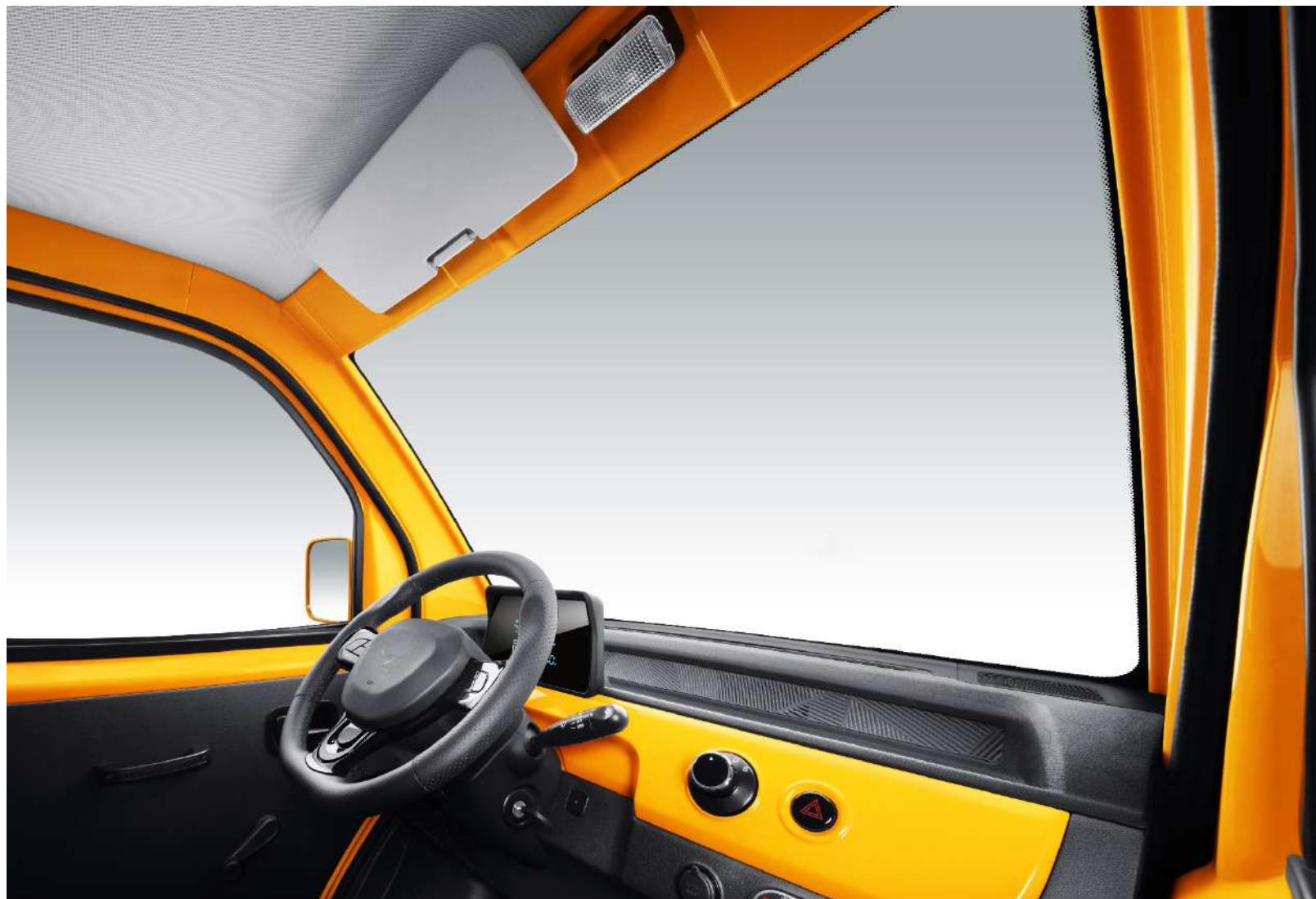



# Scene display



Community road



Small supermarket



Express



Alley



Rural road



Charging

# Part F

## 大力牛魔王 01 Chassis





大力牛魔王 01- Chassis system

## D01-chassis

**Braking system:** 大力牛魔王 01 adopts front disc and rear drum brakes, and is equipped with ABS anti lock system. ABS is controlled by 4-channel cross control of front and rear wheels, with strong braking stability; EBD auxiliary control automatically adjusts the distribution ratio of braking force, with good braking efficiency.

**Suspension system:** 大力牛魔王 01 front suspension adopts McPherson type independent suspension, which has good responsiveness, controllability and comfort. The rear suspension adopts gradual 2+1 leaf spring type. The gradual dependent suspension has large bearing capacity, reliable operation, strong comfort and strong anti roll ability;

**Axle:** integral electric drive axle, low noise, high transmission efficiency, rear axle ultimate load capacity 1T, strong load capacity;

**Steering system:** EPS electric power is used for steering, giving consideration to light low-speed steering, high speed stability, superior return performance, C-EPS with active return, easy and convenient handling, and ultimate experience, comparable to cars



**THANKS**